



Salient Dual pictured with the wireless Remote Control Unit (DC009DW only)

Mobile, Reliable, Simple

MEDRAD[®] Salient
Contrast Injection System

Mobile, Reliable, Simple



Salient Dual Injector System

The SALIENT™ Contrast Injection System has been engineered to deliver safety and performance with superior lifetime value.

Ideal for your contrast injection needs, Salient Dual brings innovation and value to CT suites by combining mobility, simplicity and reliability.



Control Room Monitor

- Wi-Fi enabled controls keep your Salient injector wireless and mobile
- Complete injector protocol management - all from within the control room
- Real-time injection pressure and flow metrics
- Responsive interface - with all the advantages of a touch screen tablet PC
- Injection history: Storage up to 100 past injections
- Utilizes a secure, self-contained, stand-alone peer-to-peer injector-to-monitor Wi-Fi connection



Clinical Highlights

Reduce Image Artifacts

Utilizing a saline flush supports minimizing streak artifacts that are often common as the superior vena cava empties into the right heart.

Improve and Increase Peak Contrast Enhancement

Utilizing a saline flush pushes the contrast through the vascular system.

Controlled Timing of Contrast Bolus

Utilizing a saline flush creates a tight contrast bolus that enables precise timing of contrast in the vascular system that is essential for multi-slice CT scanning.

Optimize Contrast Usage

Utilizing a saline flush can avoid pooling of contrast in veins and the contrast connection line.

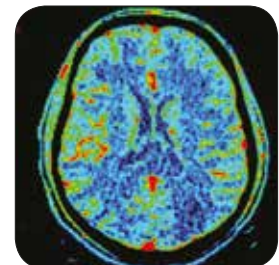
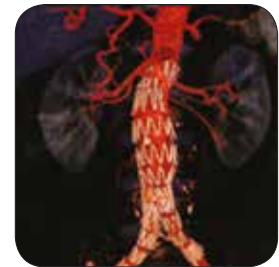

MEDRAD Salient™ Contrast Injector

Specifications Overview

Functional

Maximum pressure	300 psi
Flow rate	0.1 to 10 ml/s
Maximum volume	190 ml
Multi-phase protocols	Up to six phases Storage for 20 different named protocols
Manual fill rate	Up to 10 ml/s
Auto fill rate	Up to 10 ml/s

Controls

Base	Line power IEC Inlet On/off switch
Head	5.7" LCD touch screen Arm button On/off soft switch
Hand switch (optional)	Inject now/stop
Foot switch (optional)	Inject now/stop
Infrared Remote control	Inject now/stop

Mechanical

Weight	25.5 kg
Height	1315 mm
Floor area	500 mm x 500 mm
No. of wheels	4 castors, all individually locking

Electrical

Line voltage	100 – 230 VAC
Line frequency	50/60 Hz
Battery operation	Dual batteries, sealed lead acid
Mains power operation	Simultaneous operation and battery charging
Contrast heat maintainer <i>(one (1) included)</i>	37°C +/- 4°C, 5W

Ordering Details

PART NAME	PART NO
Salient Single Injector	DC009S
Salient Single Injector with Remote Control Unit	DC009SW
Salient Dual Injector	DC009D
Salient Dual Injector with Remote Control Unit	DC009DW
Scanner Interface Box (Optional)	DC200
Connector Tubing, for Dual (Box of 50)	ZY5152
Connector Tubing Single (Box of 50)	ZY5151
Syringe with quick fill tube (Box of 50)	ZY6322
Syringe with fill spike (Box of 50)	ZY6323
Syringe with fill spike, single LPCT (Box of 50)	ZY6324
Syringe with quick fill tube (Box of 50)	ZY6325
Foot Switch	SF0004
Hand Switch	SF0005
Wall Loader	MDL001
Heat maintainer (one (1) included)	DC022
Operations Manual - Multilanguage CD (one (1) included)	MN040015

All Imaxeon products feature a one-year warranty.

Visit our website www.imaxeon.com

Bayer, the Bayer Cross, MEDRAD, and IMAXEON are trademarks of the Bayer group of companies.

Imaxeon Pty Ltd is a subsidiary of Bayer Medical Care, Inc. MEDRAD is a federally registered trademark of Bayer Medical Care, Inc. USA. Salient is a trademark of Bayer Medical Care, Inc. Used by permission of Bayer Medical Care, Inc. In the interest of continually improving product quality the specifications shown on this brochure may change at the discretion of the manufacturer.

¹ Diagnostic images courtesy of Royal Prince Alfred Hospital.

A Quality Company

EN ISO 13485:2012



Imaxeon Pty Ltd
ABN 93 093 950 906

Rydalmere Metro Centre Unit 1, 38-46 South St Rydalmere NSW 2116 Australia
PO Box 150 Rydalmere BC NSW 1701 Australia

t + 612 8845 4999
f + 612 8845 4936

e info@imaxeon.com
w www.imaxeon.com

DIMENSIONS

Side View

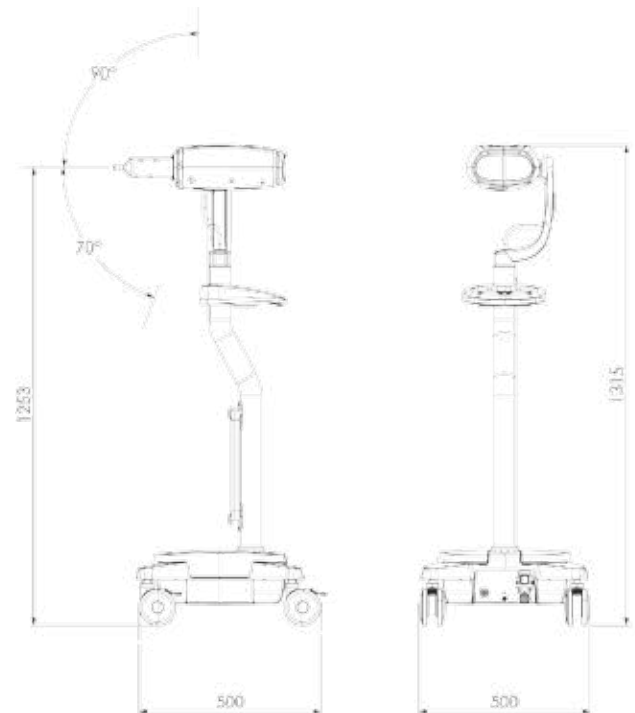

Top View

